

Figure 1 - 364266-01

1. Introduction

The OnQ Power Strip Module is for supplying 120 VAC to OnQ Service Center Enclosures. **Figure 1** shows the Power Strip Module. The Power Strip meets UL requirements of UL 1363, Standard for Relocatable Power Taps, reference File Number E213024. The Power Strip Module can be mounted in OnQ Service Center Enclosures.

2. Description

The OnQ Power Strip Module has four power outlets. The outlets are vertically mounted to allow room for OnQ power modules. It comes with a lighted on/off switch for visual confirmation of power. The power strip is a full width module.

A. Mounting in Enclosure - **Figure 2**

- 1) Align tabs on the modules with slots in enclosure.
- 2) Insert tabs by angling module away from the back of enclosure.
- 3) Rotate the module and insert fasteners on module into corresponding holes on rail of enclosure. (Plunger must be in a pulled position for fastener to engage hole.)
- 4) Push plunger in to lock module in place. Pull on module to ensure module is locked properly in place.

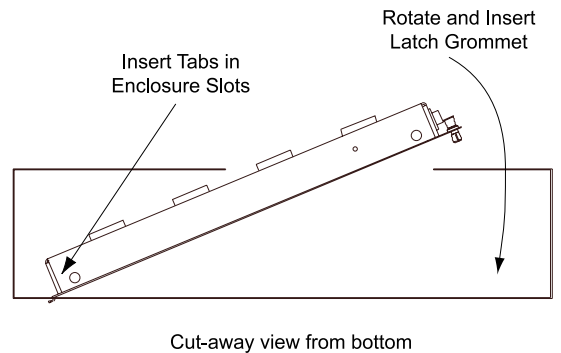

B. Applying Power

- 1) Plug power strip into standard 120 VAC outlet. It is most convenient to have a UL approved outlet installed in the bottom of the enclosure.
- 2) Turn on power switch and install power modules.

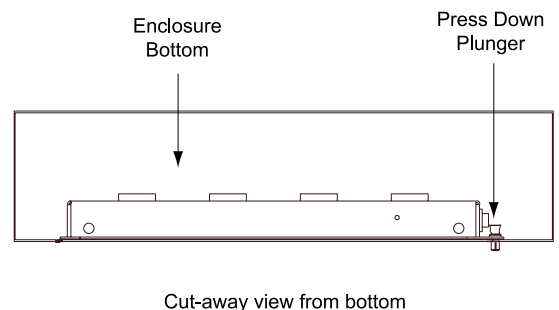

NOTE: Outlet must be installed per local electric code.

Figure 2