

Figure 1. RF Remote Control Combo

INTRODUCTION

The part no. 364697-01 OnQ RF Remote Control Combo provides remote control features for use with OnQ Home Lighting and Home Management Systems. The RF Remote Receiver features 6 general purpose and installer configurable relay outputs. The RF Remote Keyfob Transmitter buttons operate each of the 6 relays.

WIRING

The RF Remote Interface board provides connection points for wiring the RF Remote Receiver to an OnQ Home Lighting or Home Management System controller. Connection points are provided for the “Normally Open”, “Normally Closed” and “Common” terminals of each of the 6 receiver relays. 12VDC and GND (ground) connection points are provided for connecting power to the RF Remote Receiver. All connection points consist of 110 style IDC connectors for connection of category 3, 5 or 5E cable. The total cumulative length of all cabling connecting the RF Remote Receiver to the controller should not exceed 250 feet.

DEFAULT CONFIGURATION

The RF Remote Receiver’s relays are preprogrammed for Mode No. 3 (Validity) operation. The included RF Remote Transmitter will activate the relays as such:

- Keyfob Button 1 = Relay 1
- Keyfob Button 2 = Relay 2
- Keyfob Button 3 = Relay 3
- Keyfob Button 4 = Relay 4
- Keyfob Buttons 1 & 2 (simultaneously) = Relay 5
- Keyfob Buttons 3 & 4 (simultaneously) = Relay 6

ADDING A NEW KEYFOB

A total of 7 part no. 364708-01 keyfobs may be programmed into the receiver. To add a new keyfob into the receiver, use the following steps:

1. Press and release the Program button, the receiver LED will turn on solid.
2. Press and release button 1 on the keyfob until the receiver LED turns off. This should require 3 presses.

DELETING KEYFOBS

To delete all keyfobs from the receiver’s memory without affecting keyfob button and relay output mode programming, follow these steps:

1. Push and hold the receiver’s Program button.
2. Watch to see the receiver’s LED turn on for 3 seconds, turn off for 3 seconds and then turn back on.
3. When the LED turns back on, release the Program button.
4. Follow the “ADDING A NEW TRANSMITTER” instructions to add keyfobs back into the receiver.

KEYFOB AND RELAY PROGRAMMING

IMPORTANT PROGRAMMING STEPS

- If the receiver is in default mode (Mode 3, Validity), always delete all memory prior to beginning new programming
- Always ensure that the keyfob that you are going to use for programming is learned into the receiver.
- Always program the keyfob button first and then the relay output mode immediately afterwards, unless it is desired to leave the relay output mode in the default mode setting.
- All keyfob buttons may be programmed at once and then all of the output modes.

KEYFOB BUTTON PROGRAMMING

To program a keyfob button to operate a particular receiver relay, use the following steps. Multiple buttons or combinations of buttons may be associated with an individual relay. Multiple relays may be associated with a single button or combination of buttons.

1. Remove Jumper No. 1.
2. Press the Program button the number of times corresponding to the relay to be activated (1-6).
3. Watch to see that the receiver LED flashes the same number of times that the Program button was pushed.
4. Press the button or button combinations on the keyfob that are intended to operate the selected relay.
5. Watch to see that the receiver LED flashes back once to confirm.
6. Repeat steps 2-6 for any additional keyfob button programming required.
7. When programming is completed, replace Jumper No. 1.

RELAY OUTPUT MODE PROGRAMMING PROCEDURES

To change the relay output mode to something other than the default (Mode 3, Validity), follow these steps:

1. Remove Jumper No. 2.
2. Press the Program button the number of times corresponding to the relay to be activated (1-6).
3. Watch to see that the receiver LED flashes the same number of times that the Program button was pushed.
4. Press the button or button combinations on the keyfob corresponding to the output mode that is desired.
5. Verify that the receiver LED flashes once to confirm.
6. Repeat steps 2-5 for additional relay output programming.
7. When programming is completed, replace Jumper No. 2.

The relay output modes are as follows:

- Mode 1 = Momentary (1 second activation)
- Mode 2 = Latching
- Mode 3 = Validity (remains active until keyfob button is released)
- Mode 4 = Timed 30 seconds
- Mode 5 = Timed 1 minute
- Mode 6 = Timed 5 minutes
- Mode 7 = Timed 20 minutes
- Mode 8 = Strobe (.5 seconds on, .5 seconds off)

To program, use the following keyfob button/button combinations to configure the relay output modes:

- Mode 1 = Button 1
- Mode 2 = Button 2
- Mode 3 = Button 3
- Mode 4 = Button 4
- Mode 5 = Buttons 1 and 2 simultaneously
- Mode 6 = Buttons 3 and 4 simultaneously
- Mode 7 = Buttons 1 and 3 simultaneously
- Mode 8 = Buttons 2 and 4 simultaneously

INSTALLATION

The RF Remote Interface board mounts directly to any two-gang electrical box or old-work construction ring. Subsequent to termination of all cables, the RF Receiver housing may be inserted into the electrical box and the interface board may be mounted and covered with a blank two-gang cover plate.

The transmission range of the RF Remote Keyfob is approximately 400ft in open air conditions. If it is intended that the RF Remote Control is to be operated from a vehicle, best results will be obtained by locating the RF Receiver in the garage. When operated from a vehicle, the transmission range of the RF Remote Keyfob transmitter will be approximately 100 ft.

Two application modules are available for use with the RF Remote Receiver. The part no. 364645-01, ALC Distribution Module provides connection points for up to 4 of the receiver's relays. The Distribution Module supports direct wiring of the RF Remote Receiver to provide a structured wiring installation. Figure 3 below depicts a typical application where the "Normally Open" positions of relay outputs 1 thru 4 are interfaced to the OnQ Home Lighting Controller's 4 Virtual Scene Switch inputs.

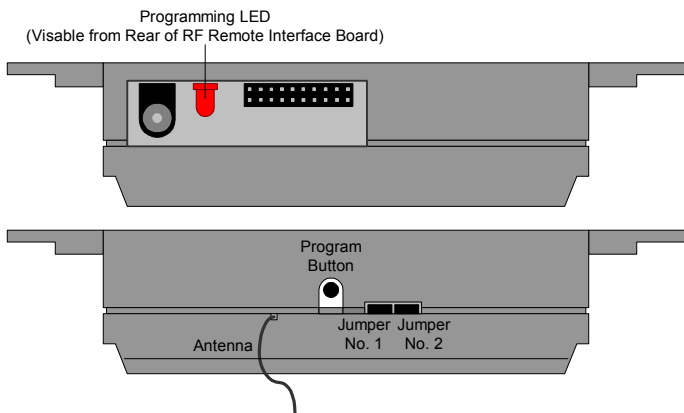

Figure 2. RF Remote Receiver Programming Features

DELETING KEYFOB BUTTONS AND RELAY OUTPUT MODES

To delete all programmed keyfob buttons and relay output mode programming, follow these steps:

1. Remove Jumper No. 1 and Jumper No.2.
2. Press and release the Program button once.
3. Watch to verify that the receiver LED flashes once to confirm.
4. Replace both jumpers.

TO CHANGE PROGRAMMING

Keyfob Buttons

- Keyfob buttons CANNOT be deleted without deleting all memory. Additional keyfob buttons can be added to control relay outputs.
- To add additional keyfob buttons, follow the directions in "KEYFOB BUTTON PROGRAMMING"
- The relay mode programming must be reprogrammed immediately after the keyfob button is added by following the steps in "RELAY OUTPUT MODE PROGRAMMING". Otherwise, the relay will revert back to the default mode (Mode 3, Validity).

Relay Output Mode

- The relay output mode can be changed at any time by following the directions in "RELAY OUTPUT MODE PROGRAMMING".

RESTORING DEFAULT MODE

To reset the receiver to the default settings, follow these steps:

1. Remove Jumper No. 1 and Jumper No.2.
2. Press and release the Program button once.
3. Watch to verify that the receiver LED flashes once to confirm.
4. Replace both jumpers.
5. Remove 12 VDC power from the receiver.
6. Apply 12 VDC power to the receiver.

OnQ Part No. 364645-01 ALC Distribution Module
Co-Located at Service Center with Controller

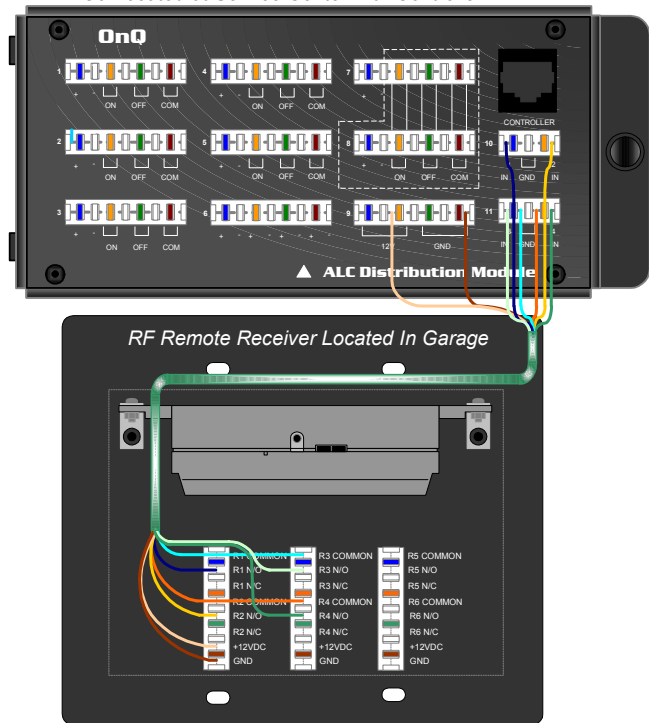

Figure 3. Example Installation, OnQ Home Lighting System Scene Lighting Control via RF Remote

RF RECEIVER	HOME LIGHTING CONTROLLER or ALC DISTRIBUTION MODULE
R1 Common	GND
R1 Normally Open (N/O)	IN 1
R2 Common	GND
R2 Normally Open (N/O)	IN 2
R3 Common	GND
R3 Normally Open (N/O)	IN 3
R4 Common	GND
R4 Normally Open (N/O)	IN 4
+12 VDC	12 VDC
GND	GND

WARRANTY

OnQ warrants to the end-user, each new ALC product to be free of defects in materials or workmanship for a period of one year from the date of original purchase from OnQ or its authorized reseller or installer. Each product is deemed warrantable under conditions of normal use and when installed and operated within OnQ specifications and in accordance with the applicable National Electrical Code and Safety Standards of Underwriters Laboratories. When determined to be warrantable, OnQ shall at its option and expense, replace any defective product with a new or reconditioned product. OnQ will continue to warrant any replaced product for a period of ninety (90) days from shipment, or through the end of the original warranty period, which ever is longer.

Table 1. Connection Matrix, OnQ Home Lighting System Scene Lighting Control via RF Remote

Alternatively, the OnQ part no. 364696-01 RF Remote Distribution Module provides connection points for all 6 of the receiver's relay outputs. Additionally, connection points are provided to allow access to each relays "Normally Open", "Normally Closed" and "Common" outputs. The RF Remote Distribution Module supports direct wiring to the RF Remote Interface board to provide a structured wiring installation.

OnQ Part No. 364696-01 RF Remote Distribution Module Co-Located at Service Center with Controller

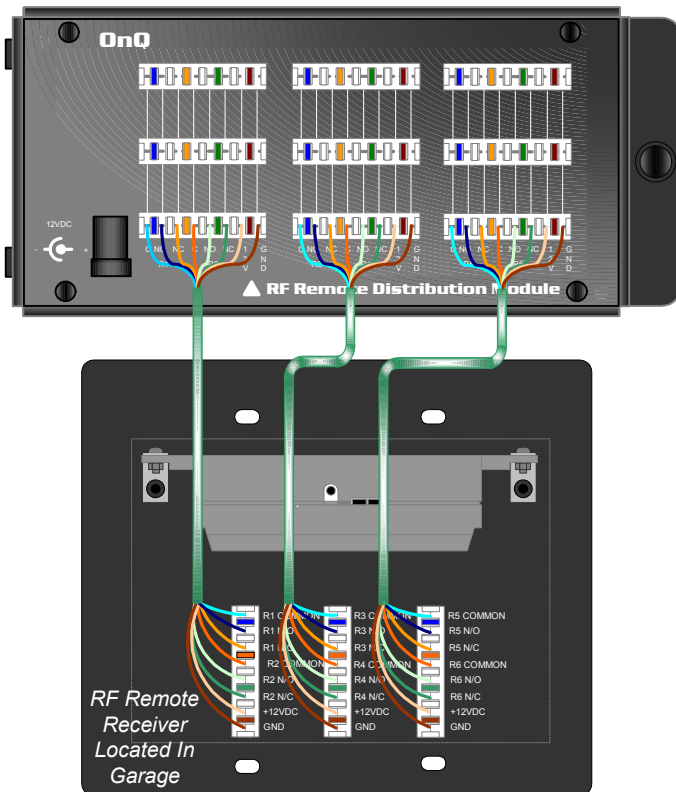

Figure 4. Example Wiring Scenario. RF Remote Distribution Module