

# INSTRUCTION/INSTALLATION SHEET

## WIRELESS ACCESS POINT (WAP)

### 1. Introduction

The On-Q Home Wireless Access Point (WAP), P/N 364711-01, is a WiFi certified 802.11 B/G compatible wireless product that provides network access to PCs, PDAs, or Ethernet Bridges (used for network access by Digital Video Recorders or Internet Radio) throughout the home without the necessity of the device being wired to a network outlet. It is generally placed in the ceiling of the top floor of the home in a central location to maximize the wireless zone coverage of the home. The supported devices must contain wireless network interface cards or capabilities in order to allow the freedom of a wireless connection. Because of most portable devices' ability to run on battery power, roaming network connections can be maintained anywhere around or outside the home, within the wireless zone.

### 2. Description

The On-Q Home Wireless Access Point is designed to be wall or ceiling mounted in a very unobtrusive manner, similar to an in-ceiling speaker or smoke detector (see *Figure 1*). As shown in *Figure 2*, it comes with all necessary parts, including a Power Over Ethernet (POE) Inserter Module, which is ideally housed in the structured wiring enclosure or may be mounted with screws to a flat surface. The POE provides operating power over the single CAT5e cable that is run to the WAP. A WAP Pre-Construction Bracket (P/N 364728-01, ordered separately) is also available to ease installation in a new construction environment (see *Figure 3*). Refer to the supplied User Guide for WAP performance and coverage information.

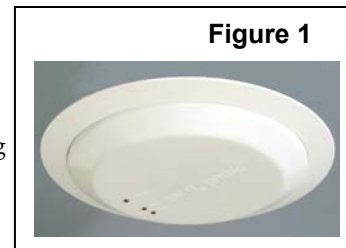

Figure 1

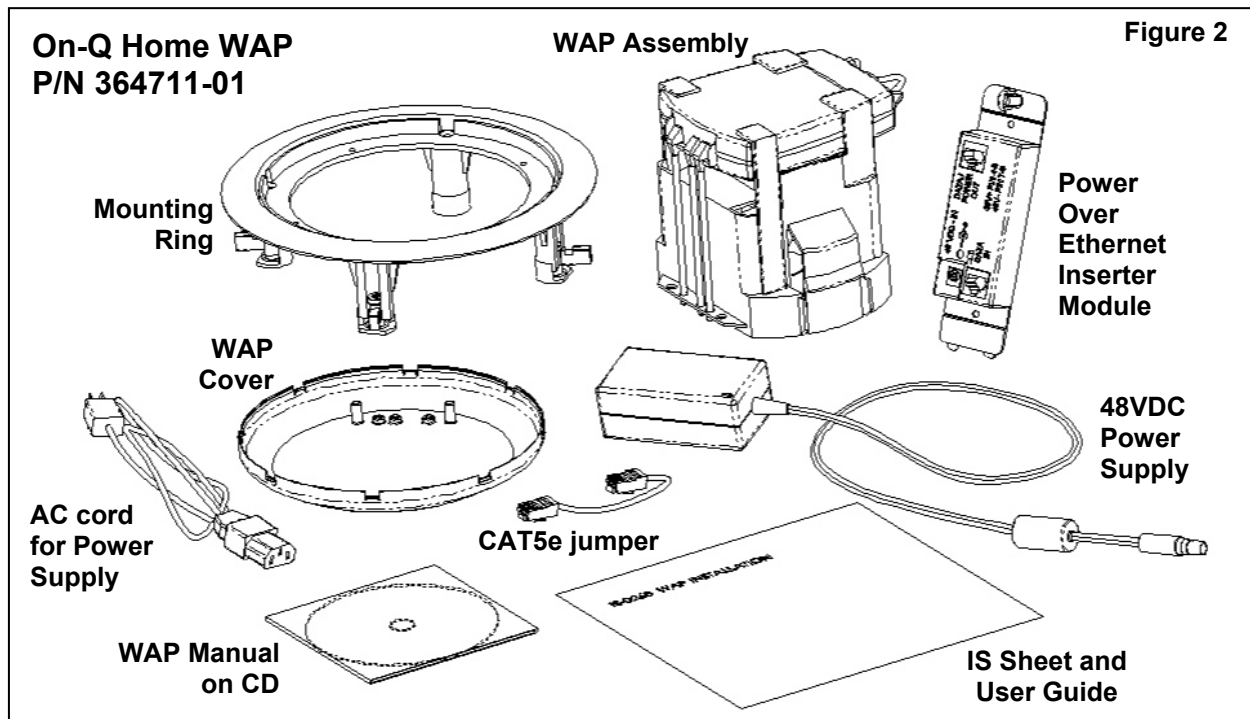

Figure 2

### 3. Installation

The On-Q Home Wireless Access Point is best installed during new construction in two steps; at "rough-in" after the

# INSTRUCTION/INSTALLATION SHEET

## WIRELESS ACCESS POINT (WAP)

IS-0268 REV. 0

Electricians are done, but prior to sheetrock being installed, and at “trim-out” after the sheetrock is installed and painted. These steps are detailed below:

“Rough-in” steps:

- a. A single CAT5e should be run in the walls from the location in the home where the On-Q Home Wireless Access Point (WAP) will be installed to the location where the POE Inserter Module will be located (leave extra cable at both ends).

**NOTE:** The preferred location for the WAP is in the ceiling of the top floor, centrally located in the home. If multiple WAPs are used, they should be located centrally, in overlapping areas.

**NOTE:** Although the On-Q Home Wireless Access Point (WAP) may be installed in ceilings or walls, it requires a minimum of 5” of mounted depth. This means that the WAP cannot be installed in 2x4 walls.

- b. (Optional Step for New Construction) At the selected WAP location, the On-Q Home Wireless Access Point Pre-Construction Bracket, is installed with two screws from the floor side across the exposed ceiling studs (for more detail, refer to IS-0269).
- c. The CAT5e can be coiled around the top of the bracket, to be pulled through after the sheetrock is installed. There are clips on the top of the bracket to tie off the CAT5e cable.

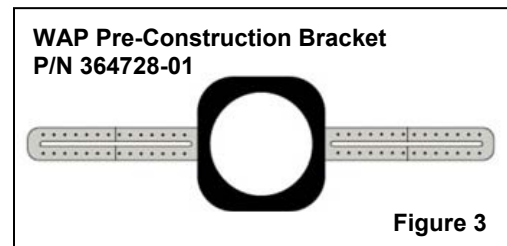

“Trim-out” steps:

- d. The WAP mounting ring should be installed first, using a Phillips screwdriver to tighten the four mounting tabs against the sheetrock or optional Pre-Construction Bracket (see Figure 4).
- e. The CAT5e that was tied off at the bracket should then be pulled through the hole in the bracket and terminated with an EZ RJ45 plug (P/N 364554-01).

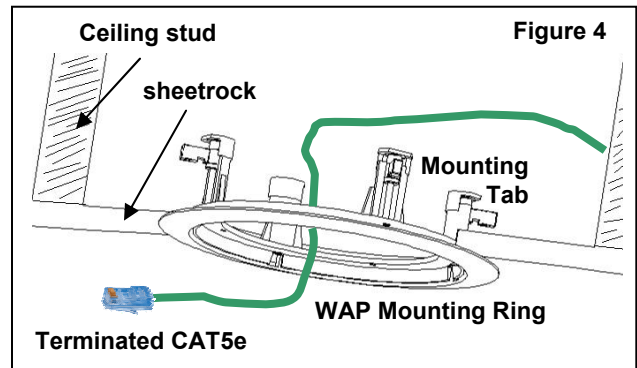

**NOTE:** Use proper tools and standard TIA 568A rules to prep and terminate the CAT5e cable, such as the On-Q Home CAT5 Cable Stripper (P/N 363292-01) and the On-Q Home EZ RJ45 Crimp Tool (P/N 364555-01).

- f. The On-Q Home Wireless Access Point (WAP) is shipped with an attached stub antenna. For better coverage in the typical residential installation, remove the stub antenna and connect the coaxial cable from the included On-Q Home antenna (see Figure 5).
- g. Next, connect the EZ RJ45 terminated CAT5e cable to the WAP Assembly.

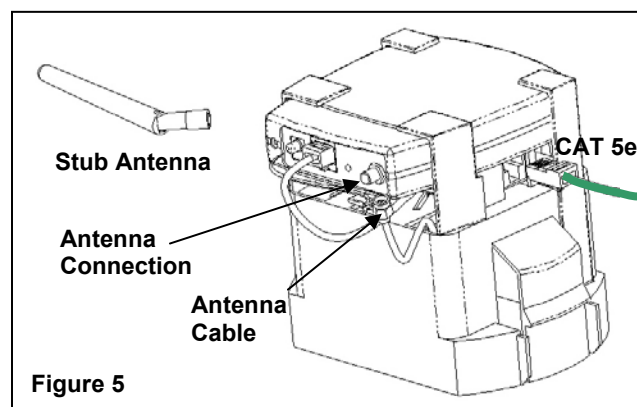

# INSTRUCTION/INSTALLATION SHEET

## WIRELESS ACCESS POINT (WAP)

IS-0268 REV. 0

- h. To physically install the WAP Assembly, push the unit through the mounting ring until the Mounting Ring Clasps snap into place (see *Figure 6*).
- i. Then install the center cover, making sure the tabs in the cover line up with the holes on the WAP Assembly. This will insure that the light pipes from the status lights on the WAP are properly aligned (see *Figure 7*).

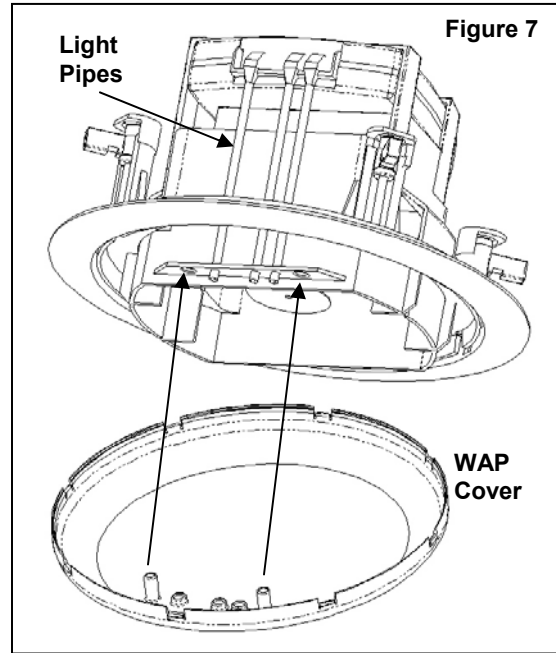
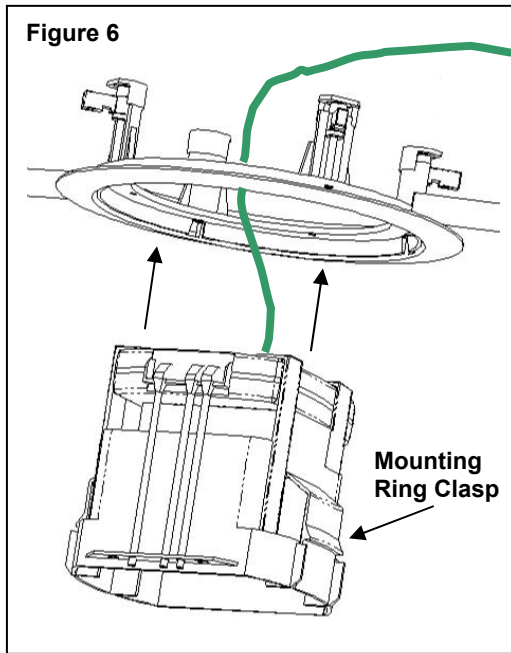

- j. In the structured wiring enclosure the CAT5e from the WAP can be terminated at a Network Interface Module or with an EZ RJ45 plug which is then connected directly to the output of the Power over Ethernet (POE) Inserter Module (see *Figure 8*).
- k. A supplied CAT5e patch cable is then connected from the input RJ-45 jack of the Power over Ethernet Module to one of the LAN ports on the On-Q Home or third party Router, or directly to a Broadband Modem (see *Figure 8*).
- l. The Power over Ethernet Inserter Module is powered with a 48 Volt DC power supply which needs to be plugged in to an AC source (see *Figure 8*).
- m. When the 48 VDC Power Supply is plugged in to an active AC Source, verify that the Power LED is lit on the POE.
- n. Next, verify that the Power LED is lit on the WAP.
- o. If you connected to an active network, verify that the Network Activity LED is lit on the network access device and on the WAP.

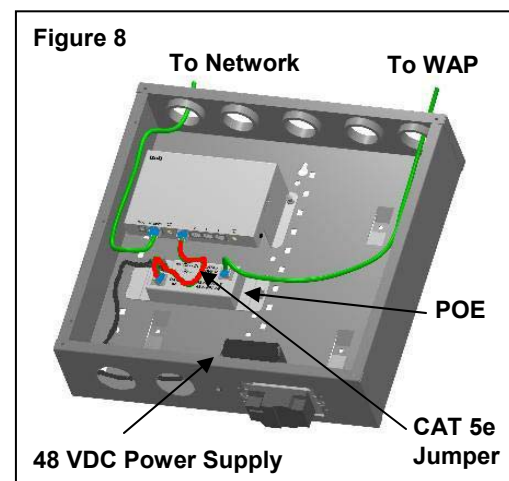

# INSTRUCTION/INSTALLATION SHEET

## WIRELESS ACCESS POINT (WAP)

IS-0268 REV. 0

- 
- p. Then, verify the Wireless LED is lit on the WAP.
  - q. Follow the steps in the supplied user guide for configuration and troubleshooting of the On-Q Home Wireless Access Point.

**NOTE:** The Wireless Access Point is shipped with minimum security configured. You may want to make it more secure for your specific application, following the steps in the supplied user guide.